



## 8301 CARBON STEEL

Manually operated ANSI 300 class, high performance Lug style butterfly valves.

- Temperature range -20°F to 446°F, 150 WSP.
- ISO 5211 direct mounting pad/square stem.
- Compact design, easy access to packing.
- Replaceable seat design.
- NACE MR0175.
- FC170-2 compliant.
- CRNs available upon request.
- Multiple V-ring stem packing.
- RPTFE seats, metal seats upon request.
- 10 position locking handle.
- Soft seat leakage protection - Class VI.
- Metal seat leakage protection - Class V.
- 14" to 24" sizes available upon request.

8301-9301: size 2" to 12".

8321-9321: METAL SEATED VERSION - size 2" to 12".

8341-9341: API 607 FIRE SAFE VERSION - size 2" to 12".

G8301-G9301: GEAR OPERATED VERSION - size 2" to 12".

### Technical specifications

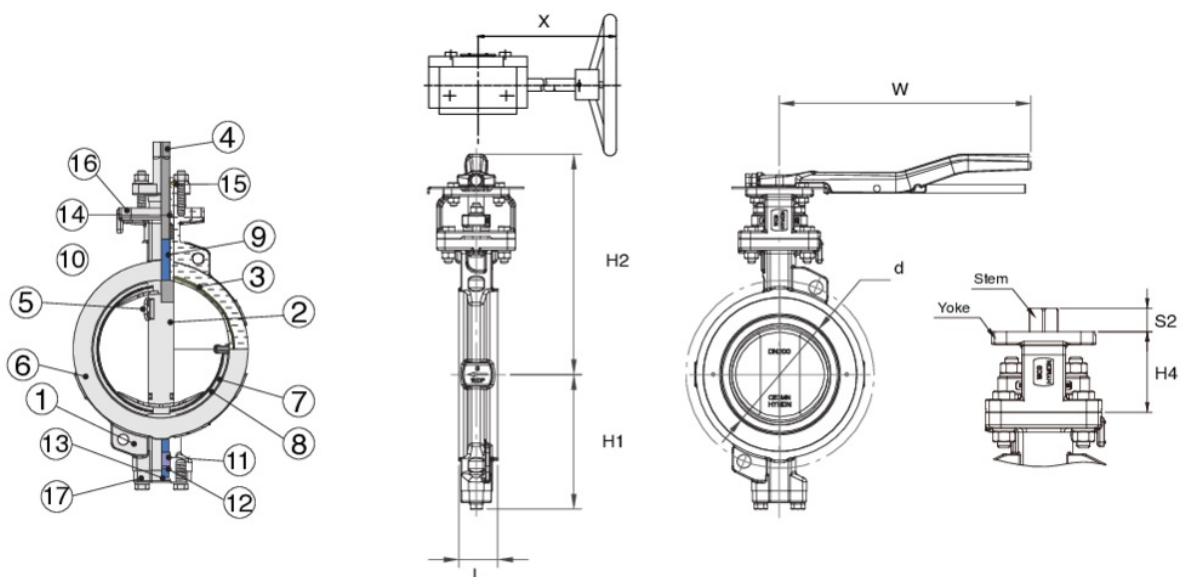

POSITION	PART NAME	MATERIAL	N.° PIECES
1	BODY	A216 Gr. WCB	1
2	DISC	A351 Gr. CF8M	1
3	SEAT	Carbon-filled PTFE	1
4	STEM	A182-F316	1
5	TAPER PIN	A182 Gr. F316L	2
6	RETAINER RING	A351 CF8M	1
7	SPRING	A182-F316	1
8	LOCK PIN	PTFE	1
9	STEM BUSH	PTFE + SS316L	2
10	GLAND PACKING	Carbon-filled RTFE	1
11	THRUST RING	A351 CF8M	1
12	THRUST PLATE	PTFE + SS316L	1
13	GASKET	PTFE	1
14	GLAND BUSH	A351 CF8M	1
15	ANTI-BLOWOUT PIN	A182-F316	1
16	GLAND FLANGE	A351-CF8	1
17	BOTTOM COVER	A351 Gr. CF8M	1

SIZE	L	D	D1	D	H1	H2	W	X	H4	S2	STEM	YOKE ISO	CV	BREAK TORQUE	WEIGHT LBS
10"	2.76	12.83	15.94	9.29	10.00	10.24	-	8.82	3.94	0.94	22	F10	3199	1407	66.0
12"	3.19	14.76	19.09	11.06	11.73	11.42	-	8.46	3.94	1.14	27	F12	4672	2266	101.0
2"	1.77	3.74	5.91	1.81	4.65	9.21	8.66	6.06	2.76	0.63	14	F07	70	133	11.0
2 1/2"	1.89	4.41	7.09	2.40	4.96	9.53	8.66	6.06	2.76	0.63	14	F07	150	150	13.0
3"	1.89	4.96	7.48	2.99	5.28	10.24	8.66	6.06	2.76	0.63	14	F07	227	13.45177	15.0
4"	2.13	6.10	9.06	3.78	5.67	10.63	8.66	146.06	F072.76	0.63	14	F07	473	283	20.0
5"	2.24	7.24	10.04	4.65	7.01	11.42	11.81	6.06	2.76	0.75	17	F07	605	381	26.0
6"	2.24	8.46	11.02	5.63	7.48	12.01	11.81	6.06	3.15	0.75	17	F07	1010	487	29.0
8"	2.44	10.51	13.58	7.40	8.43	13.78	15.75	8.82	3.15	0.83	17	F10	20004	894	46.0