

## 100003 CHECK VALVE

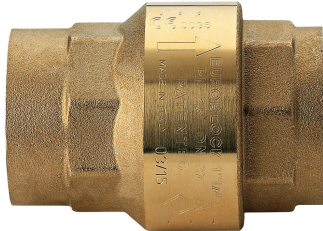

- High flow rate brass, FNPT threaded, in-line spring loaded check valve.
- Pressure rating: size 1/4"-2" 400 WOG / 2 1/2"-4" 175 WOG.
  - Soft seat for bubble tight shutoff, spring loaded for fast seating action.
  - Low cracking pressure 1/2 psi.
  - Wide temperature range: -4°F to 210°F.
  - ANSI B1.20.1 connections.
  - Flow pattern to minimize head loss.
  - Perfect sealing both at high and low pressure.
  - High technology materials to ensure best resistance in any condition.
  - Not to be used for drinking water.
- 100002: NBR for water, oils and general purpose - size 3/8" to 4".  
 100003: with FKM Viton® seal for fuels and hydrocarbons. Max working temperature 366°F/125 psi steam - size 3/8" to 4".

### Technical specifications

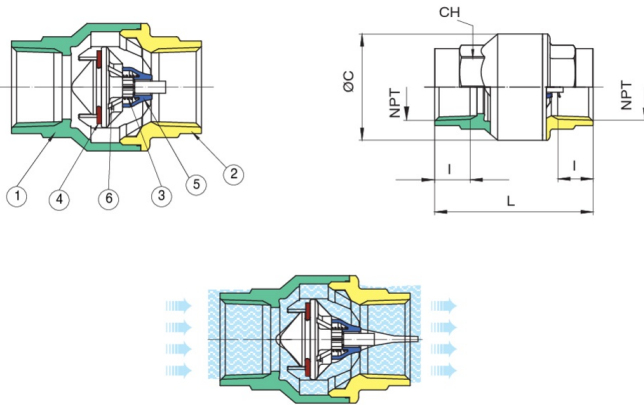

POSITION	PART NAME	MATERIAL	N.° PIECES
1	BODY	BRASS C37700	1
2	END CONNECTION	BRASS C37700	1
3	SPRING	AISI 302	1
4	SEAT	FKM (VITON)	1
5	SUPPORT	POM	1
6	DISC	POLYPHENYLENE SULFIDE	1

SIZE	I	L	ØC	CH	PSI	CV	WEIGHT (LBS)
3/8"	0.41	1.73	1.06	0.79	400	2.1	0.19
1/2"	0.54	2.22	1.36	0.98	400	9.2	0.3
3/4"	0.55	2.48	1.65	1.22	400	15.1	0.5
1"	0.66	2.85	1.93	1.5	400	22.1	0.73
1 1/4"	0.68	3.13	2.4	1.89	400	34.3	1.14
1 1/2"	0.68	3.31	2.87	2.13	400	51.9	1.56
2"	0.7	3.62	3.44	2.64	400	71.3	2.27
2 1/2"	0.93	4.37	4.39	3.27	175	90.1	4.69
3"	1.02	4.86	5.24	3.86	175	141.7	6.83
4"	1.09	5.45	6.42	5.04	175	220.7	11.61

**WARNING:** This product can expose you to chemicals including lead, which is known to the State of California to cause cancer and birth defects or other reproductive harm. For more information go to [www.p65warnings.ca.gov](http://www.p65warnings.ca.gov).