



100102 FOOT VALVE

High flow rate, brass FNPT threaded, spring loaded foot valve.

- Pressure rating: sizes 3/8"-2" 400 WOG - 2 1/2"-4" 175 WOG.
- Low cracking pressure 1/2 psi.
- Wide temperature range: -4°F to 210°F.
- ANSI B1.20.1 connections.
- Soft seat for bubble tight shutoff, spring loaded for fast seating action.
- Flow pattern to minimize head loss.
- Perfect sealing both at high and low pressure.
- High technology materials to ensure best resistance in any condition.
- Stainless steel 1000 micron strainer.
- Not to be used for drinking water.

100102: size 3/8" to 4".

Technical specifications

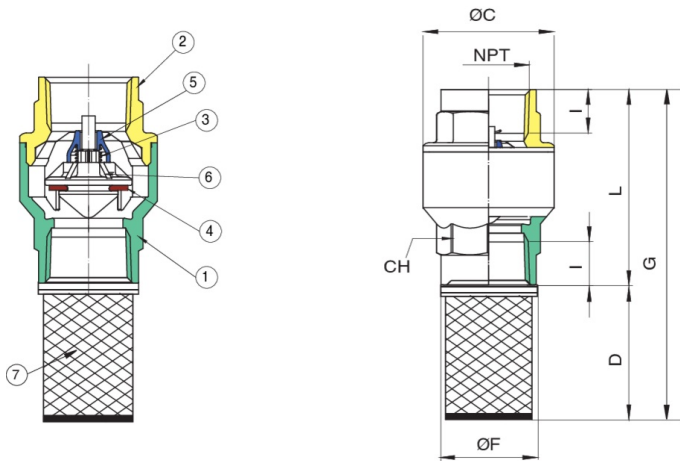

POSITION	PART NAME	MATERIAL	N.° PIECES
1	BODY	BRASS C37700	1
2	END CONNECTION	BRASS C37700	1
3	SPRING	STAINLESS STEEL	1
4	SEAT	NBR	1
5	SUPPORT	POM	1
6	DISC	POLYPHENYLENE SULFIDE	1
7	SCREEN	STAINLESS STEEL NYLON 1000 MICRON	1

SIZE	I	L	ØC	D	ØF	G	CH	PSI	CV	WEIGHT (LBS)
3/8"	0.41	1.73	1.06	1.67	0.91	3.41	0.79	400	2.1	0.23
1/2"	0.54	2.32	1.36	1.69	1.02	4.02	0.98	400	9.2	0.33
3/4"	0.55	2.56	1.65	1.89	1.26	4.45	1.22	400	15.1	0.53
1"	0.66	2.76	1.93	1.89	1.61	4.65	1.5	400	22.1	0.78
1 1/4"	0.68	2.93	2.4	2.24	1.93	5.18	1.89	400	34.3	1.32
1 1/2"	0.68	3.17	2.87	2.68	2.17	5.85	2.13	400	51.9	1.71
2"	0.7	3.37	3.46	3.27	2.64	6.63	2.64	400	71.3	2.38
2 1/2"	0.93	4.37	4.39	3.29	3.39	7.66	3.27	175	90.1	4.98
3"	1.02	4.86	5.24	3.9	3.9	8.76	3.86	175	141.7	7.26
4"	1.09	5.41	6.42	4.53	4.8	9.94	5.04	175	220.7	12.25

WARNING: This product can expose you to chemicals including lead, which is known to the State of California to cause cancer and birth defects or other reproductive harm. For more information go to www.p65warnings.ca.gov.