

## S800 CHECK VALVE



High capacity, in-line spring loaded stainless steel check valve, FNPT threaded.

- Pressure rating: size 1/4" to 2" 800 WOG - 2 1/2" to 3" 600 WOG.
- 125 WSP saturated steam.
- Wide temperature range: -4°F to 210°F.
- ANSI B1.20.1 connections.
- Soft PTFE seat for bubble tight shutoff, spring loaded for fast seating action.
- Low cracking pressure 1/2 psi.
- Flow profile designed to minimize head loss.
- Perfect sealing both at high and low pressure.
- Corrosion resistant-excellent for use on chemicals.
- Dual guided stem and disc.

S800: size 1/4" to 3".

S800FV: stainless steel FOOT VALVE - size 1/4" to 3".

### Technical specifications

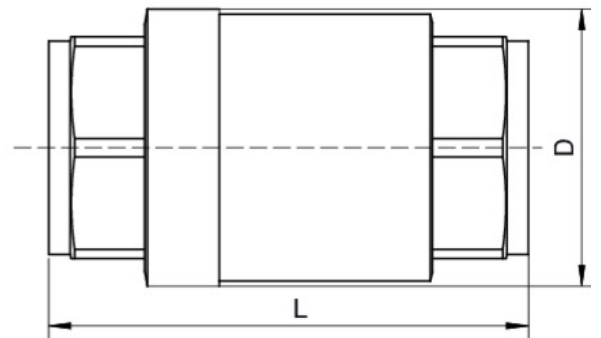
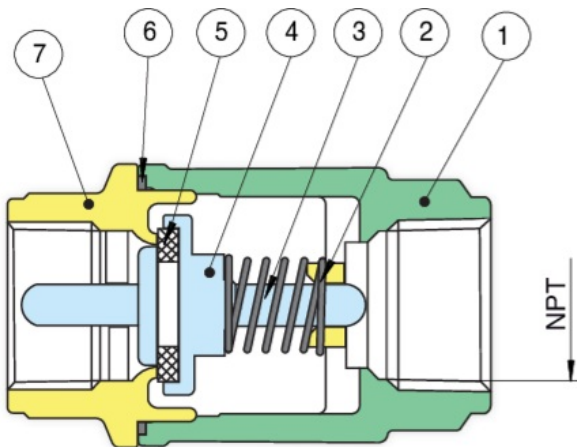

POSITION	PART NAME	MATERIAL	N.° PIECES
1	BODY	ASTM A351-CF8M	1
2	SPRING	AISI 316	1
3	CENTER GUIDE	ASTM A351-CF8M	1
4	DISC	ASTM A351-CF8M	1
5	SEAT	PTFE	1
6	GASKET	PTFE	1
7	END CAP	ASTM A351-CF8M	1

SIZE	D	L	CV	PSI	WEIGHT (LBS)
1/4"	1.35	2.31	3.5	800	0.42
3/8"	1.35	2.31	3.5	800	0.42
1/2"	1.35	2.31	5.2	800	0.4
3/4"	1.81	2.87	10	800	0.85
1"	2.13	3.5	15	800	1.3
1 1/4"	2.46	4.18	24.5	800	2.5
1 1/2"	2.88	4.93	35.2	800	3.4
2"	3.56	6	52	800	6
2 1/2"	4.53	7.12	73.8	600	12
3"	5.56	8.13	113.1	600	18