

171N LF - 172N LF COMMERCIAL STYLE

Lead free brass ball valve, FNPT threaded, full port.

- Pressure rating 600 WOG-150 WSP.
- Temperature range -4°F to 366°F.
- ANSI B1.20.1 connections.
- Blow-out proof stem, STL coated LF brass ball.
- PTFE seats, seals, and thrust washer.
- Adjustable stem packing.
- 100% electronically tested in the open and closed position at 80 psi.
- Valve to be used in fully open or fully closed position.

171N LF: LEVER HANDLE - size 1/4" to 2".

171L LF: LOCKING HANDLE - size 1/4" to 2".

172N LF: T-HANDLE - size 1/4" to 1".

171S LF: Ball and stem in stainless steel AISI 316 - size 1/4" to 2".

For sizes 2 1/2", 3" and 4" see 161N LF.

MEETS THE DESIGN CRITERIA OF MSS SP-110.

LEAD FREE COMPLIES WITH CALIFORNIA AB1953

Technical specifications

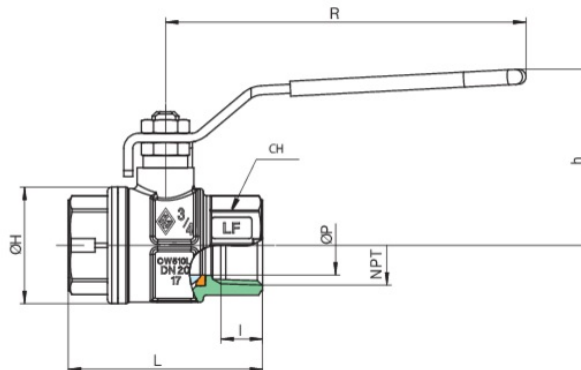
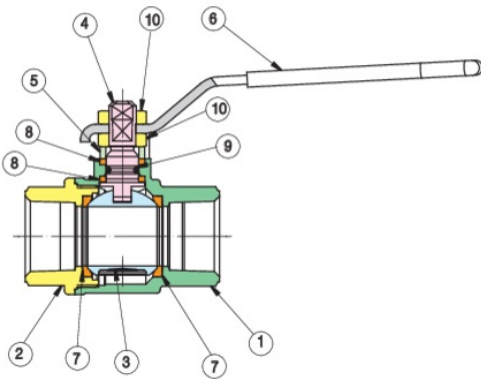

POSITION	PART NAME	MATERIAL	N.° PIECES
1	BODY	LF BRASS C28500*	1
2	END CONNECTION	LF BRASS C28500*	1
3	BALL	LF BRASS C28500*	1
4	STEM	LF BRASS C28500*	1
5	PACKING GLAND	BRASS C38500	1
6	HANDLE	STEEL DD11	1
7	BALL SEAT	PTFE	2
8	THRUST WASHER/STEM SEAT	PTFE	2
9	O-RING	NBR	1
10	NUT	STEEL CL04	2

* **Lead free** refers to the wetted surface of pipe, fittings and fixtures in potable water systems that have a weighted average lead content not more than 0.25%. Source: California health & Safety code (116875). Vermont Act 193.

SIZE	ØP	I	L	ØH	CH	R	H	CV	PSI	WEIGHT (LBS)
1/4"	0.39	0.39	1.91	0.91	0.79	3.78	1.69	6.24	600	0.31
3/8"	0.39	0.41	1.91	0.91	0.79	3.78	1.69	6.94	600	0.28
1/2"	0.59	0.54	2.34	1.3	0.98	3.78	1.83	18.84	600	0.46
3/4"	0.79	0.55	2.56	1.54	1.22	4.76	2.32	34.1	600	0.81
1"	0.98	0.66	3.07	1.93	1.5	4.76	2.48	49.71	600	1.15
1 1/4"	1.26	0.68	3.43	2.32	1.89	5.94	2.99	102.89	600	2.03
1 1/2"	1.57	0.68	3.9	2.87	2.13	5.94	3.25	265.9	600	3.01
2"	1.95	0.7	4.37	3.43	2.64	6.3	3.76	306.36	600	4.95

WARNING: This product can expose you to chemicals including lead, which is known to the State of California to cause cancer and birth defects or other reproductive harm. For more information go to www.p65warnings.ca.gov.

Certifications



UL certified



HEALTH EFFECTS



FM



CSA International



UL-250 psig



TSSA