

100012 LF CHECK VALVE

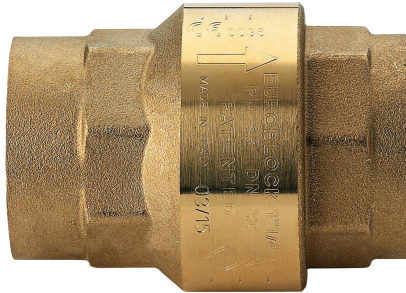

High flow rate, lead free brass, FNPT threaded, in-line spring loaded check valve.

- Pressure rating size 1/4" up to 2" 400 WOG, 2 1/2" - 4" 175 WOG.
 - Low cracking pressure 1/2 psi.
 - Wide temperature range: -4°F to 210°F.
 - ANSI B1.20.1 connections.
 - Soft seat for bubble tight shutoff, spring loaded for fast seating action.
 - Flow pattern to minimize head loss.
 - Perfect sealing both at high and low pressure.
 - High technology materials to ensure best resistance in any condition.
- 100012 LF: size 1/4" to 4".

Technical specifications

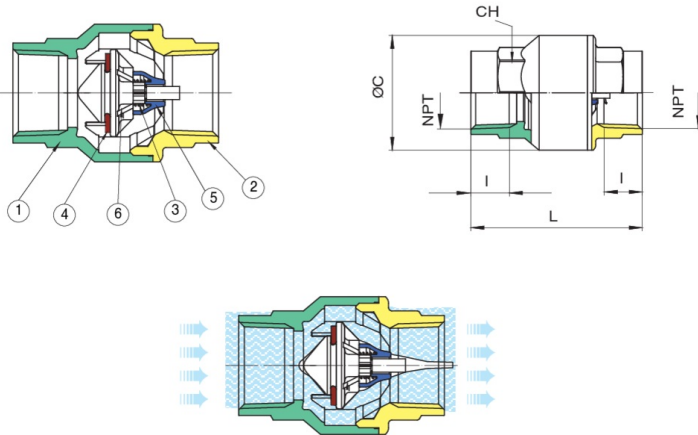

POSITION	PART NAME	MATERIAL	N.° PIECES
1	BODY	LF BRASS C28500*	1
2	END CONNECTION	LF BRASS C28500*	1
3	SPRING	AISI 302	1
4	SEAT	NBR	1
5	SUPPORT	POM	1
6	DISC	POLYPHENYLENE SULFIDE	1

* **Lead free** refers to the wetted surface of pipe, fittings and fixtures in potable water systems that have a weighted average lead content not more than 0.25%. Source: California health & Safety code (116875). Vermont Act 193.

SIZE	I	L	OC	CH	PSI	CV	WEIGHT (LBS)
1/4"	0.39	1.73	1.06	0.79	400	2.1	0.22
3/8"	0.41	1.73	1.06	0.79	400	2.1	0.19
1/2"	0.54	2.22	1.36	0.98	400	9.2	0.29
3/4"	0.55	2.48	1.65	1.22	400	15.1	0.46
1"	0.66	2.85	1.93	1.5	400	22.1	0.69
1 1/4"	0.68	3.13	2.4	1.89	400	34.3	1.13
1 1/2"	0.68	3.31	2.87	2.13	400	51.9	1.55
2"	0.7	3.62	3.44	2.64	400	71.3	2.26
2 1/2"	0.93	4.37	4.39	3.27	175	90.1	4.74
3"	1.02	4.86	5.24	3.86	175	141.7	6.9
4"	1.09	5.45	6.42	5.04	175	220.7	11.79

WARNING: This product can expose you to chemicals including lead, which is known to the State of California to cause cancer and birth defects or other reproductive harm. For more information go to www.p65warnings.ca.gov.

Certifications



UL certified

HEALTH
EFFECTS
M-GA-NSF372
NSF61

HEALTH EFFECTS