

700056

CARBON STEEL BALL VALVE



2-piece carbon steel, FNPT threaded ball valve, stainless steel ball and stem, full port.

- Pressure rating 1000 psi -150 psi steam.
- Temperature -4°F to +366°F.
- Blow-out proof stem, adjustable stem packing.
- PTFE seats, packing and thrust washer.
- 100% electronically tested in the open and closed position at 80 psi.
- TUV T.A. Luft approved.
- ISO 5211 pad with double "D" stem.
- ANSI B1.20.1 connections.

700056: size 1/4" to 2".

700056LL: WITH LOCKING HANDLE - size 1/4" to 2".

COMPLIES WITH NACE MR 0175/ISO 15156 AND NACE MR 0103.

Technical specifications

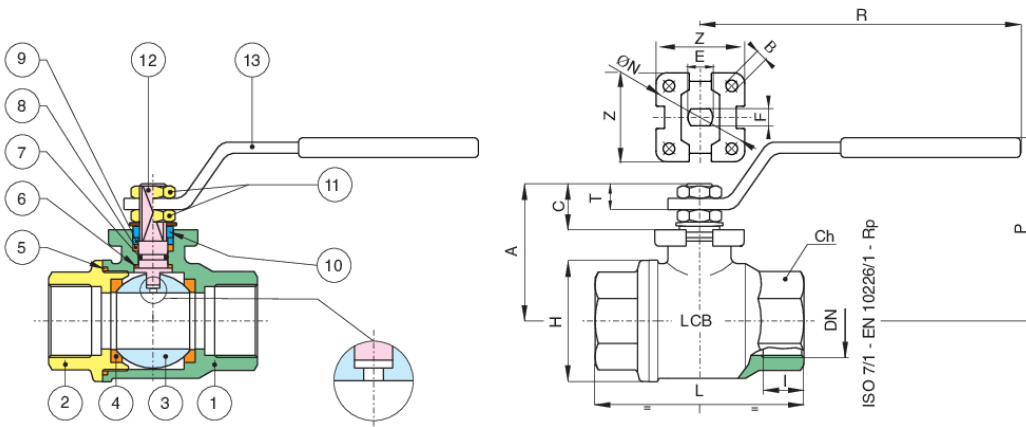

POSITION	PART NAME	MATERIAL	N.° PIECES
1	BODY	ASTM A105-WCB	1
2	END CONNECTION	ASTM A105-WCB	1
3	BALL	AISI 304-CF8	1
4	BALL SEAT	PTFE	2
5	SEAT	PTFE	1
6	THRUST WASHER	PTFE	1
7	O-RING	FKM	1
8	STEM SEAT	PTFE	1
9	PACKING GLAND	STEEL	1
10	END STOP	AISI 430	2
11	NUT	STEEL	2
12	STEM	AISI 304	1
13	HANDLE	STEEL	1

SIZE	I	L	H	CH	R	P	A	C	T	E	F	ISO 5211	B	Z	CV	PSI	WEIGHT LBS
1/4"	0.43	2.17	1.18	0.87	4.33	1.97	1.38	0.53	0.31	0.31	0.2	F03	0.22	1.42	6.36	1000	0.63
3/8"	0.45	2.17	1.18	0.87	4.33	1.97	1.38	0.53	0.31	0.31	0.2	F03	0.22	1.42	9.83	1000	0.6
1/2"	0.59	2.6	1.42	1.06	4.33	2.09	1.5	0.53	0.31	0.31	0.2	F03	0.22	1.42	22.21	1000	0.8
3/4"	0.64	3.11	1.77	1.26	5.16	2.68	2.01	0.59	0.39	0.39	0.28	F04	0.22	1.65	40.5	1000	1.46
1"	0.75	3.66	2.13	1.61	6.85	3.11	2.36	0.77	0.49	0.47	0.31	F04	0.22	1.65	74.63	1000	2.25
1 1/4"	0.84	3.86	2.52	1.97	6.85	3.27	2.52	0.77	0.49	0.47	0.31	F04	0.22	1.65	120.1	1000	3.09
1 1/2"	0.84	4.33	3.15	2.17	9.84	3.94	3.11	0.94	0.65	0.63	0.39	F05	0.26	1.97	201.32	1000	5.29
2"	1.01	5.12	3.74	2.76	9.84	4.21	3.39	0.94	0.65	0.63	0.39	F05	0.26	1.97	348.6	1000	7.91

Certifications

SIL 3



ATEX FIRE-SAFE (On request)