



BONOMI
NORTH AMERICA



630LL FNPT - 631LL SW - 632LL BW

Direct mount high performance 3-piece full port ball valves with locking lever.

- Class 900 sizes 1/4" to 2", class 600 sizes 2 1/2" - 4".
 - Carbon steel-2220 psi, stainless steel-2160 psi (1/4" - 2"), carbon steel-1480 psi, stainless steel-1440 psi (2 1/2" - 4").
 - Working steam pressure to 250 psi.
 - Temperature range: -50°F to 550°F.
 - ISO 5211 mounting pad/square stem.
 - TFM-4215 ball seats.
 - Standard latch locking handle.
 - Conforms to ANSI 16.34, ANSI B1.20.1 thread depths, NACE MR0175.
 - Fire Safe to API 607.
 - Grounded ball and stem.
 - Standard 316 stainless steel ball and stem in carbon steel models.
- 640LL (NPT) - 641LL (SW) - 642LL (BW): CARBON STEEL VALVE WITH PEEK SEATS - size 1/4" to 4".
740LL (NPT) - 741LL (SW) - 742LL (BW): STAINLESS STEEL VALVE WITH PEEK SEATS - size 1/4" to 4".

Available options: oval handle, stem extension or fugitive emissions bonnet.

Technical specifications

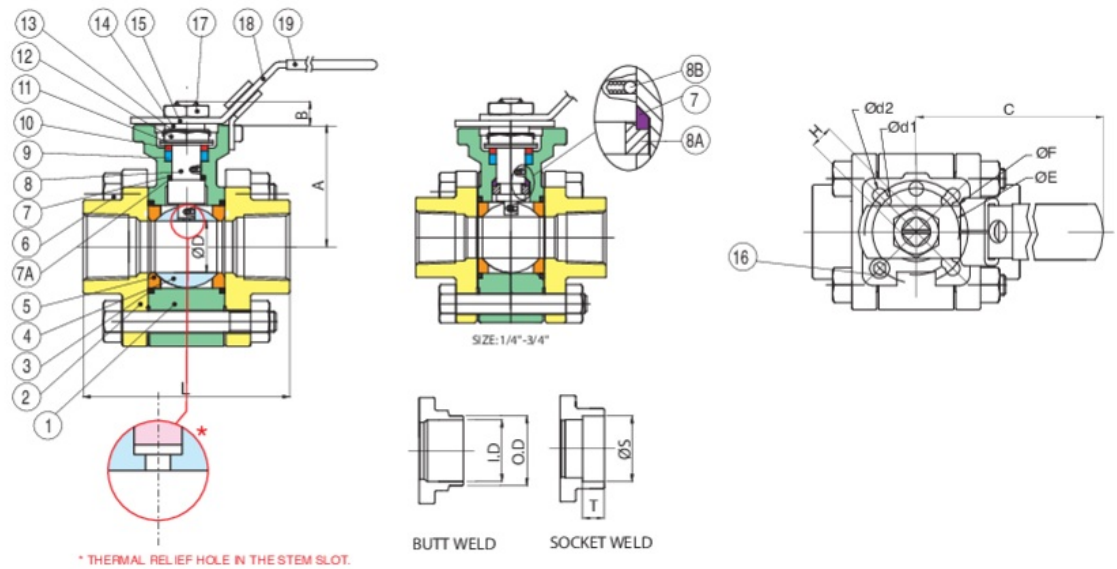

POSITION	PART NAME	MATERIAL	N.° PIECES
1	BODY	WCB	1
2	END CAP	WCB	2
3	GASKET (BODY)	TFM	2
4	BALL	AISI 316	1
5	BALL SEATS	TFM 4215	2
6	BOLTS	AISI 304	*
7	THRUST WASHER	TFM	1
7	THRUST WASHER	PEEK	1
8	STEM	AISI 316	1
8	HALF SPLIT RING	AISI 316	1
8	ANTI-STATIC	AISI 316	1
9	STEM PACKING	TFM	1
10	GLAND WASHER	AISI 304	1
11	DISK WASHER	AISI 301	1
12	STEM NUT	AISI 304	1
13	NUT STOP	AISI 304	1
14	SPACE WASHER	AISI 304	1
15	PLATER	AISI 304	1
16	STOP IN	AISI 304	1
17	HANDLE NUT	AISI 304	1
18	HANDLE	AISI 304	1
19	HANDLE COVER	PLASTISOL	1

* Depending on size.

SIZE	A	B	ØD	ØD1	ØD2	ISO 5211 ØE	ISO 5211 ØF	H MM	L	SW ØS	SW T	BW(80#) O.D	BW(80#) I.D	TORQUE IN-LBS	CV	WEIGHT LBS
1/4"	1.81	0.37	0.43	0.24	0.24	F03	F04	9	2.61	0.56	0.44	0.55	0.3	71	8.5	1.5
3/8"	1.81	0.37	0.49	0.24	0.24	F03	F04	9	2.61	0.69	0.44	0.67	0.43	71	8.5	1.5
1/2"	1.89	0.37	0.59	0.24	0.24	F03	F04	9	2.76	0.86	0.5	0.84	0.54	107	21	2.2
3/4"	2.08	0.47	0.79	0.24	0.24	F04	F05	11	3.62	1.07	0.56	1.05	0.74	133	50	3.8
1"	2.32	0.47	0.98	0.24	0.27	F04	F05	11	4.13	1.33	0.63	1.31	0.96	160	90	5.6
1 1/4"	2.44	0.57	1.26	0.27	0.36	F05	F07	14	4.37	1.67	0.69	1.66	1.28	222	110	7.0
1 1/2"	2.75	0.57	1.49	0.27	0.36	F05	F07	14	4.88	1.92	0.72	1.91	1.5	416	240	11
2"	3.54	0.75	1.97	0.36	0.45	F07	F10	17	5.91	2.41	0.84	2.38	1.94	736	400	22
2 1/2"	4.13	0.71	2.5	0.36	0.45	F07	F10	17	6.5	2.91	0.87	2.88	2.32	1461	700	32
3"	4.68	0.98	3.07	0.45	0.53	F10	F12	22	7.68	3.54	1	3.51	2.9	2213	980	44
4"	5.67	0.98	3.89	0.45	0.53	F10	F12	22	9.65	4.54	1.26	4.51	3.83	3368	1700	87

