



740H NPT

Stainless steel direct mount high pressure, high temperature 3-piece full port ball valve with locking lever.

- High pressure to 3600 psi.
 - Temperature range: +150°F to 500°F.
 - High temperature to 500°F max.
 - Direct mounting to ISO 5211/square stem.
 - PEEK seats.
 - Standard latch locking handle.
 - Conforms to ANSI B16.34, ANSI B1.20.1 thread depths, NACE MR0175.
- 740H (NPT) - 741LL (SW) - 742LL (BW): size 1/4" to 1".

Technical specifications

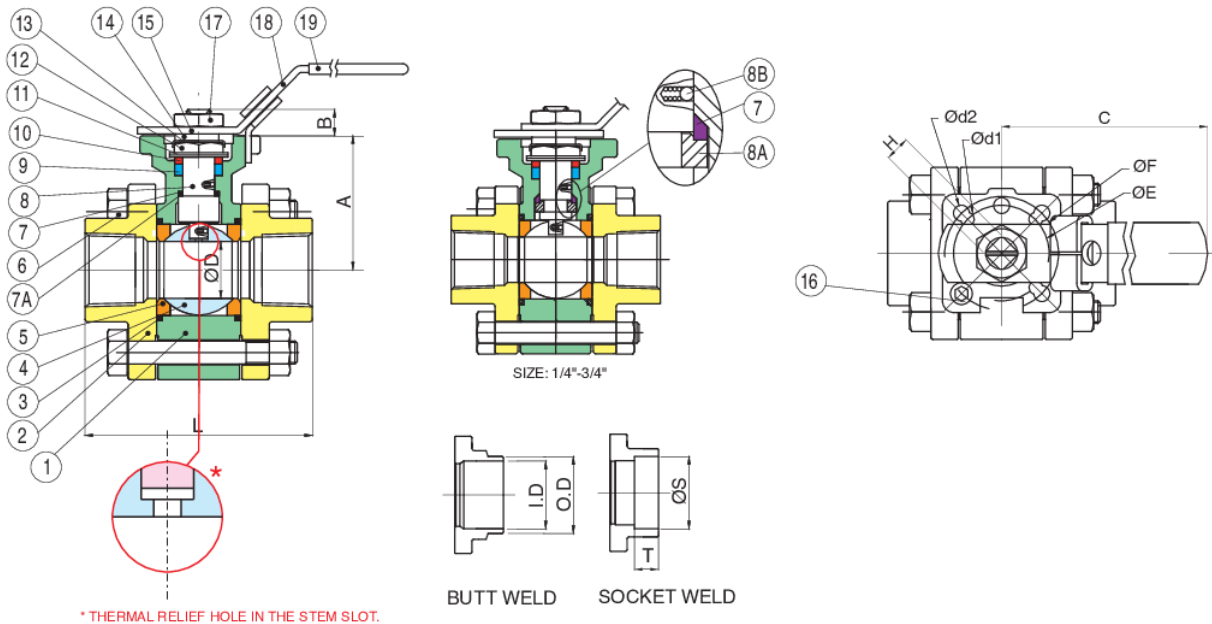

POSITION	PART NAME	MATERIAL	N.° PIECES
1	BODY	CF8M	1
2	END CAP	CF8M	2
3	GASKET (BODY)	TFM	2
4	BALL	AISI 316	1
5	BALL SEATS	PEEK	2
6	BOLTS	AISI 304	*
7	THRUST WASHER	TFM	1
7	THRUST WASHER	PEEK	1
8	STEM	AISI 316	1
8	HALF SPLIT RING	AISI 316	1
8	ANTI-STATIC	AISI 316	1
9	STEM PACKING	TFM	1
10	GLAND WASHER	AISI 304	1
11	DISK WASHER	AISI 301	1
12	STEM NUT	AISI 304	1
13	NUT STOP	AISI 304	1
14	SPACE WASHER	AISI 304	1
15	PLATER	AISI 304	1
16	STOP IN	AISI 304	1
17	HANDLE NUT	AISI 304	1
18	HANDLE	AISI 304	1
19	HANDLE COVER	PLASTISOL	1

* Depending on the size.

SIZE	A	B	ØD	ØD1	ØD2	ISO 5211 ØE	ISO 5211 ØF	H MM	L	SW ØS	SW T	BW (80#) O.D	BW (80#) I.D	TORQUE IN. LBS.	CV	WEIGHT LBS.
1/4"	1.81	0.37	0.43	0.24	0.24	F03	F04	9	2.61	0.56	0.44	0.55	0.3	71	8.5	1.5
3/8"	1.81	0.37	0.49	0.24	0.24	F03	F04	9	2.61	0.69	0.44	0.67	0.43	71	8.5	1.5
1/2"	1.89	0.37	0.59	0.24	0.24	F03	F04	9	2.76	0.86	0.5	0.84	0.54	107	21	2.2
3/4"	2.08	0.47	0.79	0.24	0.24	F04	F05	11	3.62	1.07	0.56	1.05	0.74	133	50	3.8
1"	2.32	0.47	0.98	0.24	0.27	F04	F05	11	4.13	1.33	0.63	1.31	0.96	160	90	5.6