

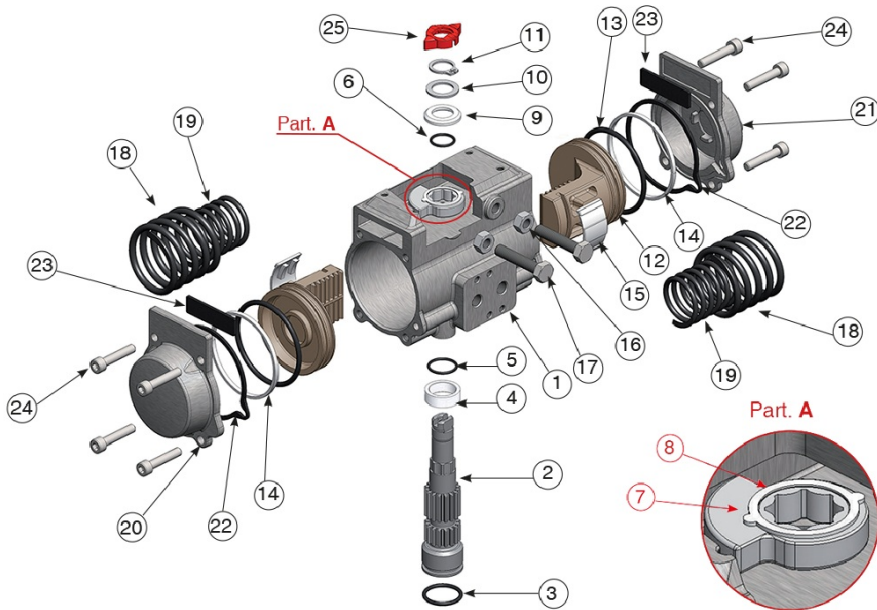

MOD. 75

Technical specifications

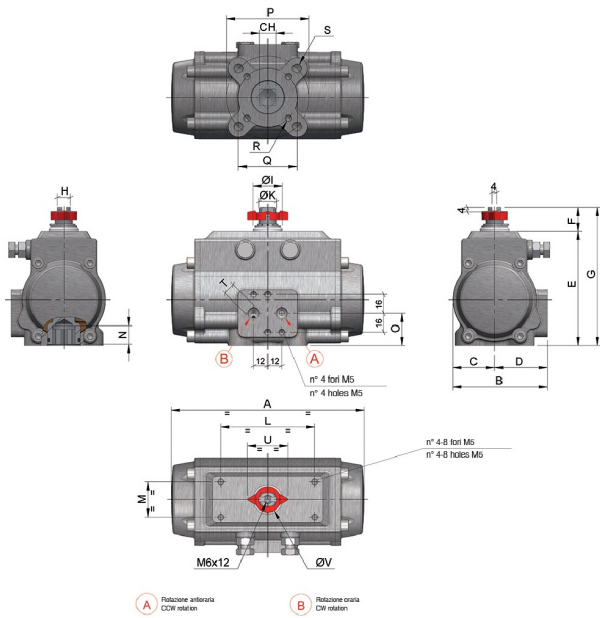



POSITION	PART NAME	MATERIAL	TREATMENT	N.° PIECES
1	Body	Stainless steel	-	1
2	Anti-blowout pinion	Stainless steel	-	1
3*	O-ring	FKM (VITON)	-	1
4*	Spacer ring	pom	-	1
5*	O-ring	FKM (VITON)	-	1
6*	O-ring	FKM (VITON)	-	1
7	Cam	Stainless steel	-	1
8	Spacer	pom	-	1
9*	Spacer	pom	-	1
10	Washer	Stainless steel	-	1
11	Snap ring	Stainless steel	-	1
12	Piston	Die cast aluminium	Hard anodized	2
13*	O-ring	FKM (VITON)	-	2
14*	Antifriction ring	pom	-	2
15*	Thrust block	pom	-	2
16	Stop bolt retaining nut	Stainless steel	-	2
17	Stop bolt	Stainless steel	-	2
18	External spring	Acciaio-steel	Powder coating (bonderizing)	See spring setting
19	Internal spring	Acciaio-Steel	Powder coating (bonderizing)	See spring setting
20	Left end cap	Stainless steel	-	1
21	Right end cap	Stainless steel	-	1
22	End cap seats	NBR	-	2
23	End cap seats	FKM (VITON)	-	2
24	End cap fixing screw	Stainless steel	-	8
25	Position indicator	Thermoplastic rubber TPE	-	1

*Parts subject to wear.

SIZE	PATTERN ISO 5211	CH	A	B	C	D	E	F	G	H	ØI	ØK	L	M	N	O	P	Q	R	S	T NPT	U	ØV
75	F05-F07	17	8.27	3.72	1.65	2.07	4.53	0.79	5.32	0.51	1.14	0.75	3.15	1.18	0.75	1.38	2.76	1.97	1/4-20 UNC 2Bx0.31"	5/16-18 UNC 2Bx0.47"	1/8"	1.65	1.14