

## 631LLV3-V6-V9 (SW)



Carbon steel direct mount 3 piece V-port ball valve with locking lever, sizes 1/4" to 4".

- Temperature range -4°F to 406°F.
- Class 900 sizes 1/4" to 2, Class 600 sizes 2 1/2" to 4".
- Working pressure: 2200 psi (1/4" to 2"), 1480 psi (2 1/2" to 4").
- ISO 5211 mounting pad/square stem.
- TFM-4215 ball seats.
- Standard latch locking handle.
- Conforms to ANSI B16.34, ANSI B1.20.1 thread depths, NACE MR0175.
- Fire Safe to API 607-6th edition.
- Working steam pressure 250 psi.
- Standard SS 316 and stem in carbon steel models.
- Temperature range: -50°F to 550°F.

250 PSI STEAM

**NEW**

### Technical specifications

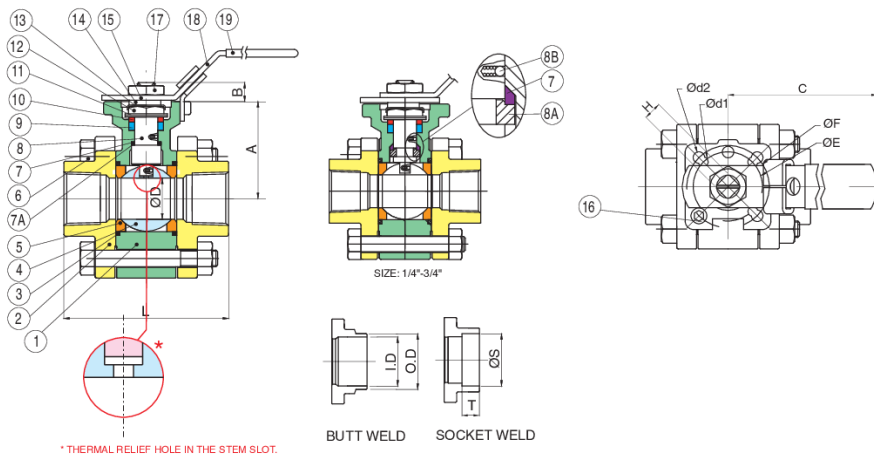

POSITION	PART NAME	MATERIAL	N.° PIECES
1	BODY	WCB	1
2	END CAP	WCB	2
3	GASKEY (BODY)	TFM	2
4	BALL	SS 316	1
5	BALL SEATS	TFM 4215	2
6	BOLTS	SS 304	*
7	THRUST WASHER	TFM	1
7	THRUST WASHER	PEEK	1
8	STEM	SS 316	1
8	HALF SPLIT RING	SS 316	1
8	ANTI-STATIC	SS 316	1
9	STEM PACKING	TFM	1
10	GLAND WASHER	SS 304	1
11	DISK WASHER	SS 301	1
12	STEM NUT	SS 304	1
13	NUT STOP	SS 304	1
14	SPACE WASHER	SS 304	1
15	PLATER	SS 304	1
16	STOP IN	SS 304	1
17	HANDLE NUT	SS 304	1
18	HANDLE	SS 304	1
19	HANDLE COVER	PLASTISOL	1

SIZE	A	B	ØD	ØD1	ØD2	ISO 5211 ØE	ISO 5211 ØF	H MM	L	SW ØS	SW T	BW (40#) LD	BW (40#) O.D	BREAK TORQUE IN. LBS	WOG	WEIGHT LBS
1/4"	1.81	0.37	0.43	0.24	0.24	F03	F04	9	2.61	0.56	0.44	0.55	0.36	71	2000	1.5
3/8"	1.81	0.37	0.49	0.24	0.24	F03	F04	9	2.61	0.69	0.44	0.67	0.5	71	2200	1.5
1/2"	1.89	0.37	0.59	0.24	0.24	F03	F04	9	2.76	0.86	0.5	0.84	0.63	107	2200	2.2
3/4"	2.08	0.47	0.79	0.24	0.24	F04	F05	11	3.62	1.07	0.56	1.05	0.82	133	2200	3.8
1"	2.32	0.47	0.98	0.24	0.27	F04	F05	11	4.13	1.33	0.63	1.31	1.05	160	2200	5.6
1 1/4"	2.44	0.57	1.26	0.27	0.36	F05	F07	14	4.37	1.67	0.69	1.66	1.38	222	2200	7.0
1 1/2"	2.75	0.57	1.49	0.27	0.36	F05	F07	14	4.88	1.92	0.72	1.91	1.61	416	2200	11
2"	3.54	0.75	4.97	0.36	0.45	F07	F10	17	5.91	2.41	0.84	2.38	2.06	736	2200	22
2 1/2"	4.13	0.71	2.5	0.36	0.45	F07	F10	17	6.5	2.91	0.87	2.88	2.47	1461	1480	32
3"	4.68	0.98	3.07	0.45	0.53	F10	F12	22	7.68	3.54	1	3.51	3.07	2213	1480	44
4"	5.67	0.98	3.89	0.45	0.53	F10	F12	22	9.65	4.54	1.26	4.51	4.02	3368	1480	87