



GS15P SWING CHECK VALVE

Stainless steel PTFE seated swing check valve.

- Pressure rating 360 psi: 1 1/2" - 20" and C/F: 24".
 - Temperature range -65°F to +390°F.
 - Can be installed in two positions (upward and horizontal flow).
 - Can be used with ANSI 150 flanges.
 - Low head loss.
 - Different materials available upon request.
 - EPDM, NBR, or FKM seats available upon request.
- GS15P: size 1 1/2" to 24".

NEW

Technical specifications

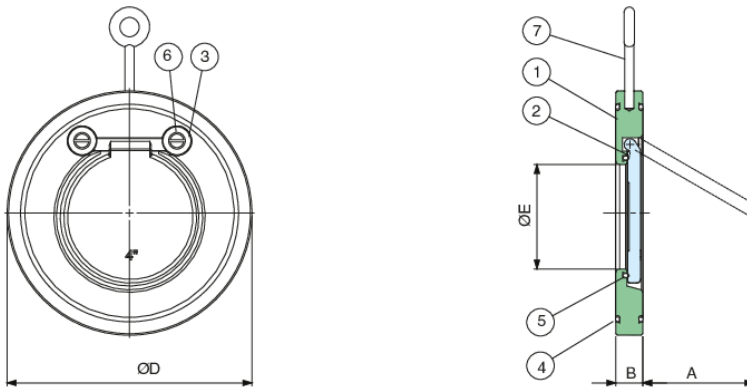

POSITION	PART NAME	MATERIAL	N.° PIECES
1	BODY	A316	1
2	CLAPET	A316	1
3	WASHER	A316	2
4	SCREW	A316	2
5	O-RING	PTFE	2
6	O-RING	PTFE	1
7	EYE SCREW	STEEL	1

WARNING: This product can expose you to chemicals including lead, which is known to the State of California to cause cancer and birth defects or other reproductive harm. For more information go to www.p65warnings.ca.gov.