

97L150

L-PORT

3-way ANSI 150 direct mount stainless steel, block body, full port ball valve.

- ANSI 150 full port flanged.
- ISO 5211 mounting pad.
- Reinforced TFE seats and seals.
- Multiple chevron style stem packing.
- Investment cast and sand cast body construction.
- Meets International standards.
- 1000 PSI WOG.
- T and L port designs.

97L150 - 97T150: sizes 1/2" to 6".

Technical specifications

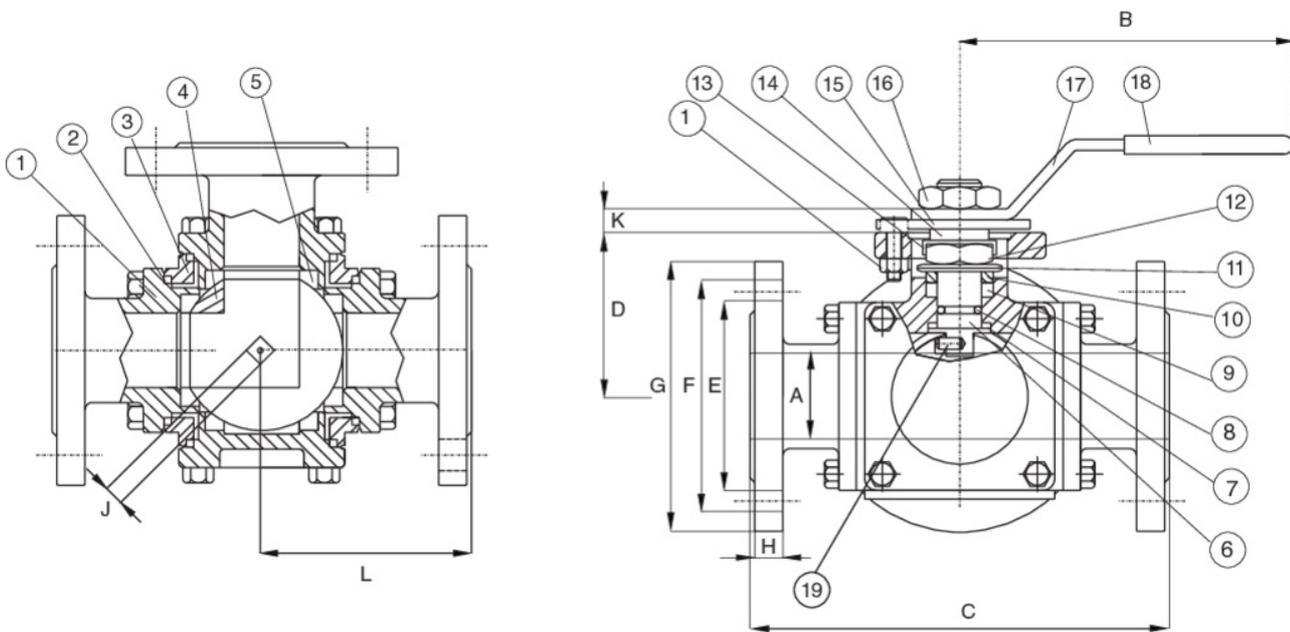

POSITION	PART NAME	MATERIAL	N.° PIECES
1	FLANGED ENDS	A351 CF8M	3
2	GASKET	PTFE	4
3	BODY	A351 CF8M	1
4	BALL	AISI 316	1
5	BALL SEATS	PTFE	4
6	THRUST WASHER	RPTFE	1
7	STEM	AISI 316	1
8	O-RING	FKM (VITON)	1
9	STEM PACKING	PTFE	1
10	GLAND	AISI 304	2
11	DISC WASHER	AISI 301	1
12	STEM NUT	AISI 304	1
13	NUT STOP	AISI 304	1
14	SPACE WASHER	AISI 304	1
15	STOPPER PLATE	AISI 304	1
16	HANDLE NUT	AISI 304	1
17	HANDLE	AISI 304	1
18	HANDLE SLEEVE	VINYL	1
19	INSERT PIN	AISI 304	1
20	STOP PIN	AISI 316	1
21	STOP PIN NUT	AISI 304	1
22	BOLTS	AISI 304	8

SIZE	A	B	C	D	E	F	G	H	J	K	L	ISO 5211	CV	BREAK TORQUE	WEIGHT LBS
1/2"	0.59	5.12	5.98	1.61	1.39	2.38	3.5	0.44	9	11	2.99	F03/F04	6	110	-
3/4"	0.79	6.5	6.57	1.93	1.69	2.76	3.86	0.44	11	14	3.29	F04/F05	16	125	-
1"	0.98	6.5	7.48	2.17	2.01	3.13	4.25	0.44	11	14	3.74	F04/F05	31	325	-
1 1/2"	1.5	8.07	8.66	2.91	2.87	3.88	5	0.56	14	18	4.33	F05/F07	75	500	-
2"	1.97	12.8	9.96	3.66	3.62	4.74	5.98	0.62	17	23	4.98	F07/F10	140	900	-
2 1/2"	2.44	15.75	11.81	4.67	4.13	5.49	7.01	0.7	22	25	5.91	F10	210	1200	-
3"	2.99	19.69	12.01	5.37	5	6	7.48	0.75	22	25	6.01	F10	375	1500	-
4"	3.78	25.59	14.51	6.16	6.18	7.5	9.02	0.94	22	25	7.26	F10	670	3000	-
6"	5.91	47.24	16.81	6.28	8.5	9.51	11	1	36	36	8.41	F12	4743	5000	-