



## 724102-V36-V6-V9

### DIRECT MOUNT CARBON STEEL WAFER V-BALL VALVE

Direct mount Carbon steel ANSI class 150 flanged V-ball valve 30-60, 60, 90 degrees V ports.

- Temperature range -4°F to +366°F.
- Antistatic stem device.
- TFM-MPTFE ball seats and thrust washer standard.
- Triple stem seals - two Viton (FKM) O-rings and one PTFE seat.
- ISO 5211 Pad.
- Low torque design.

724102V36 - 724102V6 - 724102V9: size 1" to 4".

### Technical specifications

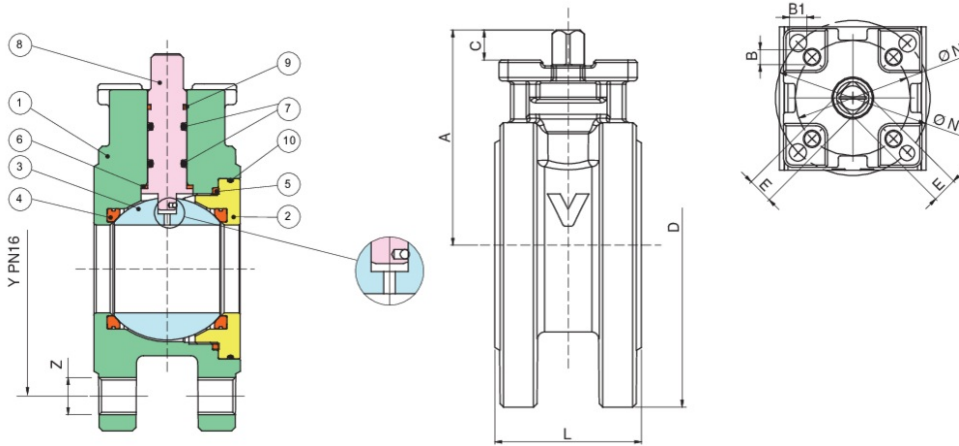



POSITION	PART NAME	MATERIAL	N.º PIECES
1	BODY	A352/LCB	1
2	END CONNECTION	ASTM A105	1
3	BALL	A351-CF8/A182-F304	1
4	BALL SEAT	TFM-MPTFE	2
5	BODY SEAT	PTFE	1
6	THRUST WASHER	TFM-MPTFE	1
7	O-RING	FKM (VITON)	2
8	STEM	A564-TP630 H1150D (17-4-PH)	1
9	STEM SEAT	PTFE	1
10	O-RING	FKM (VITON)	1

SIZE	D	Y	Z	L	A	C	E	ISO 5211 ØN	B	B1	BREAK TORQUE (IN/LBS)	CV	WEIGHT LBS
1"	4.33	3.35	4x5/8"	1.89	2.76	0.43	9	F03/F05	0.22	0.28	74.63	89	5.29
1 1/4"	5.12	3.94	4x5/8"	2.13	3.23	0.39	9	F03/F05	0.22	0.28	120.1	116	7.72
1 1/2"	5.51	4.33	4x3/4"	2.5	3.66	0.51	11	F05	0.26	-	201.32	151	9.92
2"	6.1	4.92	8x5/8"	3.23	4	0.53	11	F05/F07	0.26	0.35	348.6	177	14.77
2 1/2"	7.09	5.71	8x3/4"	4.06	5.06	0.73	17	F07	0.35	-	596.66	284	24.03
3"	7.48	6.3	8x3/4"	4.8	5.43	0.71	17	F07	0.35	-	1009.48	390	30.87
4"	8.66	7.09	8x3/4"	5.98	6.02	0.73	17	F07	0.35	-	1577.34	531	46.08